

RECARO SPORT

Operating instructions

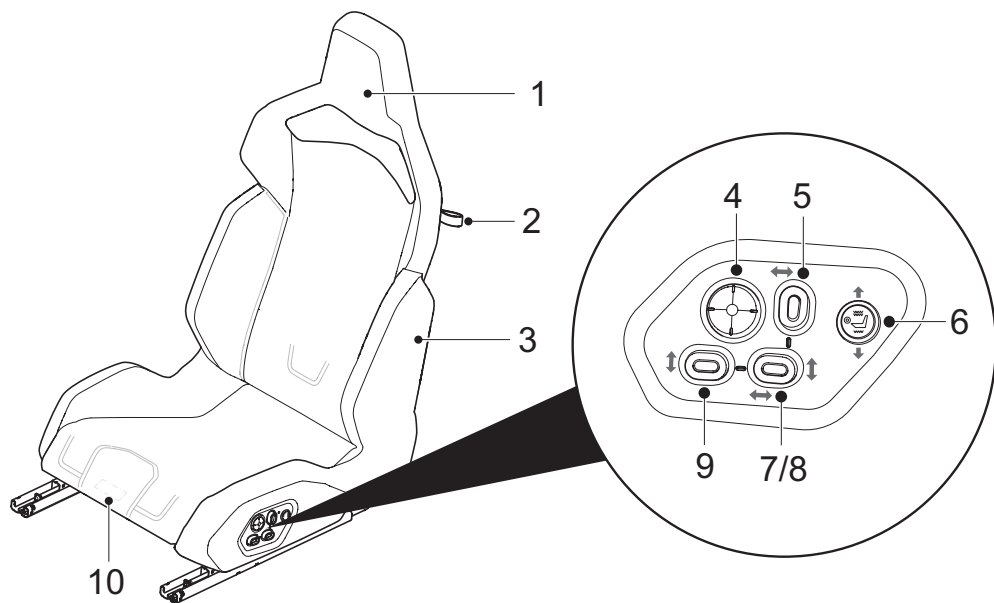

1. Your RECARO seat has these functions



Pos.		For vehicles with 3 doors		For vehicles with 5 doors	
		Without side airbag	With side airbag	Without side airbag	With side airbag
1	Headrest	Integrated	Integrated	Integrated	Integrated
2	Tilting the backrest forward	Manual	Manual	-	-
3	Side airbag (SAB)	-	Yes ¹⁾	-	Yes ¹⁾
4	Adjusting the lumbar support (lordosis)	Electrical	Electrical	Electrical	Electrical
5	Adjusting the backrest angle	Electrical	Electrical	Electrical	Electrical
6	Seat heating	Optional	Optional	Optional	Optional
7	Adjusting the seat height	Electrical	Electrical	Electrical	Electrical
8	Adjusting the distance between seat and pedals	Electrical	Electrical	Electrical	Electrical
9	Adjusting the seat surface angle	Electrical	Electrical	Electrical	Electrical
10	Adjusting the seat surface length	Manual	Manual	Manual	Manual

¹⁾ A RECARO Sport with a side airbag may only be installed in vehicles equipped with a side airbag in the seat.

Important

The ignition must be switched on to operate all electric functions.

2. For your safety

Please note

In choosing RECARO, you have opted for a high-quality car seat. However, even a RECARO seat can only fulfil its function in a vehicle if it is operated correctly.

- To ensure that your seat is always positioned correctly, first adjust it to your own personal comfort requirements. These instructions are intended to help you make correct adjustment. You should read through the following pages carefully to ensure this is the case.

Have a good trip!

 WARNING
Risk of an accident if you try to adjust the seat while the vehicle is in motion.
■ Adjust your seat when the vehicle is stationary only.

Exclusion of liability

RECARO assumes no liability for this RECARO seat and any damage resulting from its use if it is not used in accordance with these instructions or if the seat or its components are modified in any way. RECARO accepts no liability for any damage which is due to incorrect installation.

Any modification or misuse of the RECARO seat void the warranty.

2.1. On these operating instructions

These operating instructions contain specific safety instructions for RECARO seats, which are based on and supplement your vehicle manual.

- Attach these operating instructions to your vehicle manual.
- Always carry these operating instructions with you in your vehicle as long as the RECARO seat remains fitted inside your vehicle.

NOTICE

- If your vehicle contains a side airbag, please observe the following safety instructions for side airbag systems.

Symbols and key words

The following symbols and key words are used in these instructions:

 DANGER

An immediate danger that will result in serious injury or death.

 WARNING
--

A possibly dangerous situation that can result in serious injury or death.

 CAUTION
--

A possibly dangerous situation that can result in minor injury or material damage.

2.2. Safety instructions for side airbag systems

These instructions also apply if your RECARO seat is not equipped with a side airbag and the serial-production side airbag is deactivated.



WARNING

Risk of serious injury

- Never carry out repairs on, make adjustments to, install or remove parts of the airbag system.
- Only trained technical staff may carry out work on the side airbag system.
- Contact a specialist company in such cases, particularly to deactivate side airbags and carry out installation work on side airbag systems or seat covers.

NOTICE

Please observe the information in your vehicle manual and pay special attention to the following points:

- Functions and mode of operation for each of the side airbag indicator lamps
- Side airbag system activation
- Repair, maintenance and special notices
- Side airbag deactivation and other systems affected by this, such as belt tensioners, head airbags and passenger airbags.
- Instructions on the use of child seats
- Instructions on the distances to front airbags, belt path and seat position

Safety instructions on storing seats with a side airbag after removal



DANGER

Risk of explosion by pyrotechnic material in the side airbag

Risk of death or serious injury

Side airbags contain pyrotechnic material. For this reason, seats with a side airbag must be stored in such a way that children are unable to access them.

- Secure the electrical connections further to protect the contacts from improper use, soiling and damage. The corresponding connectors are supplied with the installation kit or can be purchased through specialist dealers.
- Store removed seats in a place where they are protected against misuse and are not exposed to extreme weather conditions or wide fluctuations in temperature.
- The side airbag module is still active even if the seat has been removed. Only trained technical staff may work on removed seats with a side airbag.

Special notes for RECARO seats with an integrated side airbag

The side airbag is located in the side of the backrest facing the door. Its location is marked "Airbag".

Sitting securely

Side airbags are not a replacement for safety belts and can only provide additional protection if

- You have positioned your seat correctly (see "5. How to adjust your RECARO seat optimally" on page 8)
- You sit as straight and upright as possible
- You do not lean against the doors when the vehicle is under way.

The side airbag deploys at high speed in fractions of a second. Despite an optimum setting for airbag deployment, intense friction may be produced between the airbag and your body. We therefore strongly recommend wearing suitable clothing on parts of the body which may come into contact with the airbag (arm, chest and shoulder area).



WARNING

No protective function after the side airbag has been triggered

Risk of death or serious injury

- Seats with a triggered airbag may no longer be used.

Approval

The RECARO seat with a side airbag is tested and approved in accordance with European law. The side airbag system has **not been tested to the FMVSS** (the applicable regulations and legislation in the United States). For this reason, the RECARO side seat with a side airbag may not be shipped to, taken to or used in countries requiring an FMVSS approval.

Safety notes for accessories



WARNING

Risk of injury if incorrect decorative covers are used

- Under no circumstances may you use seat or decorative covers not expressly approved for use on a RECARO seat with a side airbag. Approval for use in the vehicle concerned will **not** suffice.

- Do not attach beverage holders or other accessories near the door and seat which could prevent the airbag from unfolding.

Disposal/scraping

- You must observe all the vehicle manufacturer's applicable safety regulations when scraping the vehicle.
- Contact a RECARO workshop if you wish to scrap the RECARO seat with side airbag.

3. How to install your RECARO seat

Please note

Care, patience and precision are required to install a seat.

- Before commencing installation, ensure that you have parked the vehicle safely and that you maintain a sure footing at all times when carrying out the work.



WARNING

Risk of injury due to improper installation

- Only trained specialist may carry out installation. Improper installation seriously impairs the RECARO seat's protective function.
- Only RECARO components (such as consoles) that are authorised for the relevant vehicle type may be used to install the seat. In particular, the seat may only be combined with other parts (parts by other manufacturers, etc.) if these have been expressly tested and approved or recommended by RECARO.

When using other consoles, there is the danger, among other things, that the seat will not be fitted correctly, the console will not absorb the loads adequately or the belt catch will not function correctly. This can cause injuries and accidents with severe consequences

Consoles and built-in components

Consoles are important safety components. Components that have not been approved (or tested) can lead to serious consequences in the event of a traffic accident.

Components from other sources can damage the seat, due to an inadequate position of the seat belt, for example.



WARNING

Risk of injury due to belt tensioners and pyrotechnic material in airbags

- "Authorisation to handle pyrotechnic restraint systems in a workshop and storage area" in accordance with legislation governing explosives is required for modifications to belt tensioners and installation work on airbags and their control lines.
- Special care must be taken when working on airbags in seats and in vehicles. If seats with airbags are installed or removed incorrectly, the airbags may deploy unintentionally and cause injury and damage.

4. How to operate your RECARO seat

- Open the drawing on page 2 for reference when reading the text.

Headrest (1)

The headrest is integrated into the backrest. It cannot be adjusted separately.

Tilting the backrest forward (2) – optional

The backrest can be released and tilted forward.

- Pull the lever (2) on the backrest upwards.

The backrest will engage in its original position when you tilt it back again.

- Check that the backrest has been engaged correctly each time after it has been released.

Side airbag (3), optional

See Section “2.2. Safety instructions for side airbag systems” on page 4.

Adjusting the lumbar support (lordosis) (4)

The lumbar spine region is placed under considerable strain when sitting. Suitable support can prevent pain and injury from arising. The RECARO seat takes this fully into account with its enclosed design and ergonomic upholstery.

Two inflatable air cushions are located under the backrest cushion. You use the switch (4) to pump up the air cushions or release the air.

NOTICE

Very little pumping is required thanks to the exceptional contour specification for the backrest.

- To pump up both air cushions:
Press the switch at the front.
- To empty both air cushions:
Press the switch at the rear.
- To move the lumbar support pressure point upwards:
Press the switch at the top.
- To move the lumbar support pressure point downwards:
Press the switch at the bottom.

Adjusting the backrest angle (5)

You can move the backrest to the desired position using the switch (5).

The backrest can be reclined to a lying position.

- To place the backrest in a more reclined position:
Press the switch backward.
- To place the backrest in a more upright position:
Press the switch forward.

Seat heating (6), optional

The seat heating can be adjusted to two levels using the rocker switch (6). An LED indicates the heating level.

After a certain warm-up time, the heating will reach a pleasant specified temperature on the seat surface, backrest and side bolsters.



WARNING

Electric shock and danger of overheating due to damaged heating mats

- Do not stand or kneel on the seat or place any sharp or heavy objects on the seat.
- Do not use decorative covers or any other covers on your seat so that the seat does not overheat.

- Setting the first heating level:
Press the rocker switch downwards.
The LED lights up green.
- Setting the second heating level:
Press the rocker switch upwards.
The LED lights up yellow.
- Switch off the seat heating:
Move the rocker switch into the centre position.

Adjusting the seat height (7)

You can use the switch (7/8) to adjust your RECARO seat to the required height.



CAUTION

Risk of crushing when setting the seat height

- Ensure that no-one reaches under the seat with their hands or places their feet under the seat.
- Higher seat position:
Press the switch upwards.
- Lower seat position:
Press the switch downwards.

Adjusting the distance between the seat and pedals (8)

You can use the switch (7/8) to adjust the distance between the seat and the pedals.



CAUTION

Risk of crushing when positioning the seat in a longitudinal direction

- Ensure that no-one reaches into the area where adjustment is being made or puts their feet under the seat or near the seat rails.
- Reduce distance:
Press the switch forward in the direction of travel.
- Widen distance:
Press the switch downwards against the direction of travel.

Adjusting the seat surface angle (9)

You can use the switch (9) to adjust the seat angle continuously.

- Raise front edge of the seat surface:
Press the switch upwards.
- Lower front edge of the seat surface:
Press the switch downwards.

Adjusting the seat surface length (10)

The front part of your RECARO seat features an extendible cushion section (10).

- Sit on the seat, raising your thigh slightly, to adjust the seat surface length.
- Extend seat surface:
Press the handle in the centre under the extendible cushion section upwards and slide the cushion section forward to the desired position.
- Shorten seat surface:
Press the handle in the centre under the extendible cushion section upwards and pull the cushion section towards you and into the desired position.

5. How to adjust your RECARO seat optimally

This description is designed to help you adopt a correct sitting posture. Incorrect sitting posture can cause back pain, reduced concentration and rapid fatigue. Therefore, please adjust your RECARO seat carefully in the sequence outlined below.

The seat must be positioned so that you can reach the steering wheel, pedals and controls with ease. You should also have the best possible field of vision in all directions, as well as an optimum view of the vehicle's instrument panel and controls.

Step 1: Distance of seat from the pedals

- Move your buttocks as close as possible to the backrest.
- Adjust the seat position in relation to the pedals in such a way that your legs are slightly bent when you press on the pedals.



Step 2: Backrest angle

- Move your the shoulders as close as possible to the backrest.
- Position the angle of the backrest so that you can reach the steering wheel easily with your arms slightly bent. Your shoulder must stay in contact with the backrest when you turn the steering wheel.

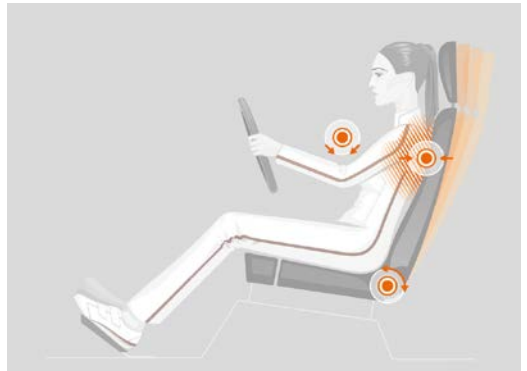

Step 3: Seat height

- Position the seat height as high as possible. This ensures you have a clear field of vision on all sides and see all display instruments.

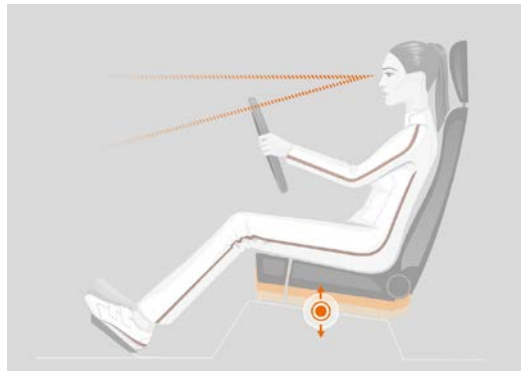

Step 4: Seating surface angle

- Ensure that the backrest angle is positioned correctly.
- Adjust the seat angle so that you can easily press the pedals down. Your thighs should rest lightly on the seat cushion without applying pressure.

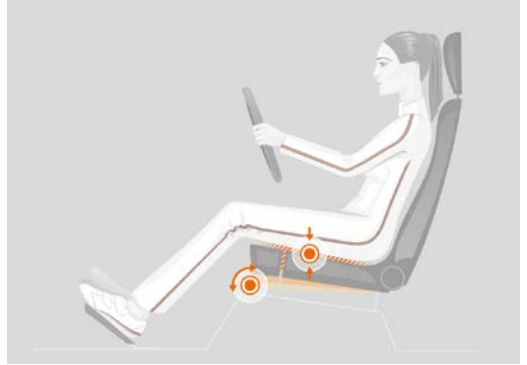

Step 5: Extending the seat surface

- Adjust the extended section of the seat surface so that your thighs rest on it until just before the knee.

Rule of thumb: 2 or 3 fingers of space between seat edge and hollow of knee

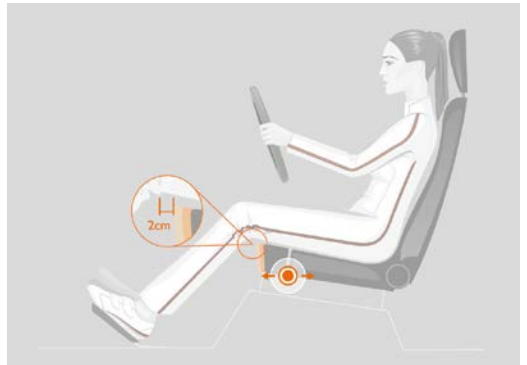

Step 6: Back support

If the lumbar spine is supported in its natural shape, the lumbar curvature support is positioned correctly.



6. Care and cleaning for your RECARO seat

NOTICE

The following cleaning and care recommendations are non-mandatory. RECARO accepts no liability for them.

- Please observe the instructions for use for the cleaning or care agent used in each case.
- Test the product on an inconspicuous spot on the seat first before applying the product to the entire seat.

6.1. Fabric covers

- Use a standard dry foam cleaner to clean the seat cover after it has been used for a long time. These cleaning agents help to freshen up the cover and restore the original brightness of the colours.
- Always clean the entire surface and not just individual areas. This prevents unattractive edges.
- Remove stains from your seat immediately. The longer you wait, the more difficult they are to clean.
- Avoid rubbing vigorously with aqueous solutions. This will roughen the upholstery fabric.

Dirt stains (e.g. blood, cola, etc.)

- Remove dirt stains with a commercial dry foam cleaner or a mild detergent. Follow the instructions for use of the cleaning agent concerned.
- Leave the covers to dry for at least 48 hours after cleaning with foam cleaners.

Greasy stains (e.g. ballpoint pen, lipstick, chewing gum, etc.)

These types of stains usually cannot be removed with foam cleaners.

- Remove greasy stains with a solvent such as petroleum ether.
- Rub the stained area carefully with a clean cloth soaked in solvent, applying superficially only

NOTICE

- Use only a very small amount of solvent. The upholstery material must not be saturated since this may corrode it, causing permanent damage in some cases.

6.2. Imitation leather covers

Imitation leather covers are highly resistant.

- Clean the covers with a mild soap solution regularly.

6.3. Smooth leather

- To maintain the dirt- and water-repellent effect, occasionally treat covers made of smooth leather with a commercial leather spray in a thin, even layer. Cover metal components on the seat before applying the spray.
- Dust smooth leather covers regularly with a soft, clean cloth.

Stubborn dirt or stains

- Use a mild detergent to remove dirt stains. The treated area must then be dried with a soft, clean cloth and then apply leather spray.

6.4. Dinamica® covers

Dinamica® micro-fibre is a highly versatile, exceptionally high-performance, high-grade material. To retain Dinamica®'s beautiful appearance for a long time, it is recommended to clean the fibre regularly and not to rub it too vigorously.

- Dust Dinamica® with a soft brush or a dry cloth or vacuum it with a vacuum cleaner.
- Wipe with a slightly dampened white cotton cloth.

NOTICE
■ Do not use coloured cloths or patterned kitchen paper as they may stain the material.

Stubborn dirt or stains

- First remove stains with deionized water. Cleaning soap is recommended for stubborn stains.
- Use a white cloth or a sponge which has been thoroughly wrung out.
- Never pour the cleaning product directly on Dinamica®.
- Rub in a circular motion from the outside inwards to prevent the stain from spreading.
- You will find more details at:
www.dinamicamiko.com

RECARO Automotive GmbH
Stuttgarter Straße 73
73230 Kirchheim/Teck
Germany

Phone: +49 (0) 7021 93-5000

E-Mail: info@recaro-automotive.com
Internet: www.recaro-automotive.com

ID NO.: 20056922 · REVISION LEVEL: A · DATE: 03/2023
RECARO®, Pole Position®, Ergomed®, RECARO Style®, Sportster CS®, Cross Speed® sind registrierte Marken der RECARO Beteiligungs-GmbH. Änderungen in Technik, Form, Farbe und Design oder die Einstellung von Produkten behalten wir uns vor. Für Druckfehler kann keine Haftung übernommen werden.
RECARO®, Pole Position®, Ergomed®, RECARO Style®, Sportster CS®, Cross Speed® are registered trademarks of RECARO Beteiligungs-GmbH. We reserve the right to make changes to the technology, form, color, and design of our products, or discontinue some of our products. We accept no liability for printing errors.