

## RECARO PRO RACER SPA / SPA XL



### UPHOLSTERY OPTIONS



**Pro Racer SPA  
Velour Black**  
071.36.0630-01



**Pro Racer SPA XL  
Velour Black**  
071.44.0630-01

### ACCESSORIES



**Steel sidemount**  
360942-01



**Flexible adaptor**  
7221002NA  
7206293NA (XL)

### Other accessories available



### FOR PROS WHO LIKE TO WIN

The tough, lightweight Pro Racer SPA is our top product for GT and touring car racing. It provides optimal body support during high g-forces, lightweight with its Carbon-Kevlar® composite shell, plus great long-term driver comfort and safety. That adds up to a competitive edge in driving performance.

The Pro Racer SPA's ergonomic S-shaped shell fits the natural curve of your spine, providing "built-in" structured lumbar support that protects against spinal compression in high-impact accidents.

### FEATURES AND ATTRIBUTES

- FIA certified and crash tested
- Certified for 5 year's use in FIA-sanctioned races
- Side-impact neck protection developed and optimized to work with head and neck safety systems
- RECARO high-integrity, Carbon-Kevlar® comfort shell
- XL seat fits average-size North American drivers; the standard size fits smaller drivers
- Aggressive thigh and torso bolstering
- High-quality, durable, shock-absorbing foam
- RECARO friction grip at shoulders
- Flame-retardant upholstery
- Suitable for 4, 5, or 6-point harnesses

## SPECIFICATIONS

	Pro Racer SPA	Pro Racer SPA XL
<b>Weight</b>	<b>15.4 lbs / 7.0 kg</b>	<b>16.5 lbs / 7.5 kg</b>
<b>Max Height</b>	<b>33.8 in / 860 mm</b>	<b>36 in / 915 mm</b>
<b>Max Length</b>	<b>32.3 in / 820 mm</b>	<b>32.3 in / 820 mm</b>

*Weight noted does not include mounting hardware*

- All mounting hardware sold separately
- Mounting hardware varies based on the vehicle the seat will be installed
- Check with your dealer / installer for fitment and necessary mounting hardware for your vehicle application

## PRO RACER SPA

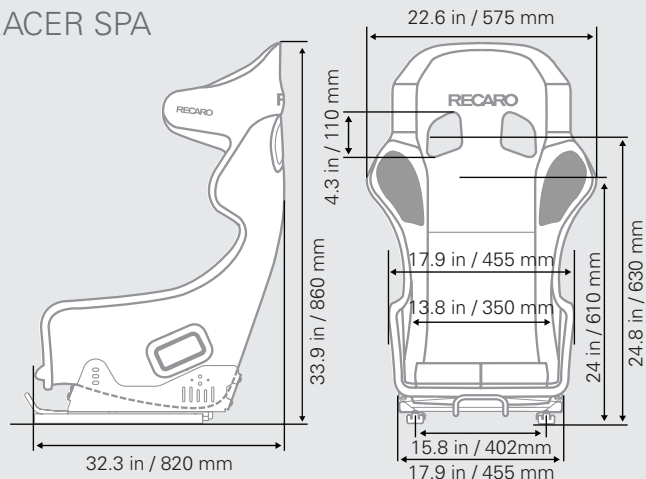

*Dimensions do not include mounting hardware*

# RACING SEATS

## OVERVIEW OF SEAT OPTIONS

- Standard features, ○ Option/accessories



**RECARO  
P1300 GT LW**

**RECARO  
P1300 GT**

**RECARO  
Podium (FIA)**

**RECARO Pro Racer  
SPA, SPA XL**

	RECARO P1300 GT LW	RECARO P1300 GT	RECARO Podium (FIA)	RECARO Pro Racer SPA, SPA XL	
USE	For GT vehicles/sports cars	●	●	●	
	For touring vehicles	●	●	●	
	For rally vehicles			●	
COMFORT	Anatomical seat contour		●	●	
	Passive Seat Air Conditioning			●	
	Paddable lumbar support	○	○	●	
	Pad Kit S (Replaceable pads for drivers of small build)	○	○		
	Pad Kit M (Replaceable pads for drivers of medium build)	●	●	○	
	Pad Kit L (Replaceable pads for drivers of large build)	○	○	○	
	Seat in XL version				○
	Flexible sidemount (fore-aft adjustment for preferred sitting positions)	●	●		○
Fixed steel sidemount		○	○	○	
LIGHTWEIGHT	Seat shell made of carbon (CFRP)	●	●	●	
	Seat shell made from carbon and aramid composite (CFRP/AFRP)			●	
	Weight: complete shell (incl. foam and upholstery, without sidemount)	~ 30.6 lbs / 13.9 kg	~ 32.4 lbs / 14.7 kg	L: ~13 lbs / 5.9 kg M: ~13.4 / 6.1 kg	SPA: ~15.4 lbs / 7 kg SPA XL: ~16.5 lbs / 7.5 kg
	Fixed aluminum sidemounts				○ SPA XL
SAFETY	Advanced Racing Seat (FIA 8862-2009)	●	●		
	Competition Seat (FIA 8855-1999)			●	
	Suitable for 4-, 5- or 6-point belts	●	●	●	●
	Suitable for head & neck restraint systems	●	●	●	●
	Shock-absorbent foam	●	●	●	●
	Highly flame-retardant upholstery	● ISO 3795	● ISO 3795	● ISO 3795	● FMVSS 302
	FIA approval for 10 years	●	●		
FIA approval for 5 years			●	●	